

Time Matters - The new seepex Smart Stator Technology.

Using "Smart Stator Technology" we have effected a fundamental improvement of pump technology by dividing the stator into two halves.

In future, progressive cavity pumps can be operated with significantly greater efficiency by utilising SST, saving time and therefore saving money.

Dividing the stator into two halves allows maintenance work on the pump to be done in a much shorter time reducing man power, effort and therefore costs. The flexible stator concept allows quick and easy pump maintenance. This could be either to change the stator or assist in the removal of foreign objects and debris.

The speed at which this happens is astonishing and saves upto 80% assembly time dependant upon the pump size.

SST also reduces the space required by the pump, as installation and dismantling of the pump occurs without having to disassemble the pump or discharge pipe.

SST is available for new pumps and also as a retrofit for existing pumps in the ranges BN and NS/N to convey a multitude of products in all industries.

Smart Stator Technology

was developed for quick and easy stator replacement enabling the removal of blockages and foreign materials without the need to remove the discharge pipe.

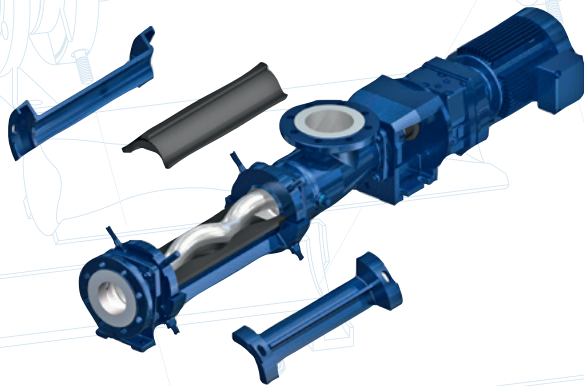

The advantages of the Smart Stator Technology at a glance.

Ease of Servicing

- Stator can be changed without the need to dismantle the discharge pipe
- Easier manual handling due to lower component weight
- No special tools are required

Significant cost savings by

- Lower maintenance costs (upto 80% shorter dependant upon pump size)
- Lower spare part prices in comparison to conventional stators
- Lower transport costs

Eco-friendly

- Only rubber halves are replaced when worn

Shorter space requirement

- No space is required to allow for stator dismantling

Let our experts illustrate to you the cost savings which could be achieved by using Smart Stator Technology in your company.

seepex pumps with Smart Stator Technology in operation.

seepex pumps with Smart Stator Technology are already operating successfully. The applications below show existing seepex pumps which have been retrofitted with the Smart Stator Technology.



And what can we get flowing for you? Your nearest contact:

Or visit www.seepex.com